

The 964 Turbo engine and engine systems  
by Adrian Streater.



1991 911 (964) Turbo, image courtesy of Aldo Vannini

The following information is a brief overview of the 964 Turbo engine and related systems. Hopefully it will provide 964 turbo owners sufficient knowledge to allow a level of understanding of how these systems operate.

**964 series Turbocharged engines**

The first turbo type 964-770 was released for model year 1991 and remained the same for model year 1992. The 964 turbo had a 964 body and chassis, structurally strengthened and given the wide body look. Mechanical systems were upgraded. The engine used was an upgraded type 930/68 engine. The modified engine for the 964 Turbo was given the designation M30/69. The main differences between the 930/68 engine and the M30/69 engine are;



Crankcase bolts similar to those used for the normally aspirated M64 engine.

New cylinder design with optimized thermal characteristics.

Stainless-steel cylinder head gasket (V2A).

Full-flow oil filter.  
Separate belt drive for 115A alternator/air conditioning compressor and engine driven fan.

930/XX turbocharged engine. Photo by Stephen Kaspar.

Continuous injection system (K-Jetronic) with oxygen sensor control with a re-designed fuel distributor assembly.

Three-way catalytic converter of metal construction.

Optimised turbo-charging system, including a larger intercooler assembly.

Boost reduced to 0.7 bar (10.2 psi), down from 0.8 bar (11.6 psi) in the 930/68

Pressure-controlled transistorized ignition system (air pressure/engine load input from the throttle body to a pressure sensor installed in ignition control unit) the with digital spark control. The ignition system introduced digital mapping for dwell and timing.

In 1993 the 3.3 litre turbocharged engine was replaced with a 3.6 litre turbocharged engine.



The new engine, the M64/50 was a turbocharged version of the M64 engine series used in normally aspirated 964s. The main differences between the M30/69 and the M64/50 engine are;

Crankcase is similar to the normally aspirated M64 series.

Crankshaft, connecting rods, intermediate shaft and the oil pump are the same as the M64 series.

Cylinder bore 100 mm.

Vibration damper on crankshaft.

Image provided by Adrian Streater

Stainless steel rings to provide cylinder head sealing.

Cylinder heads similar to the normally aspirated M64 series.

Exhaust valves are made of "P25" and do not have a sodium filling.

Chain drive housing the same as the normally aspirated M64 series.

Camshaft and timing changed, exclusive to the M64/50 engine. The camshafts are made from high-grade chilled cast iron.

Oil supply gallery similar to the normally aspirated M64 series. The oil passages plugged on the normally aspirated M64 series are opened for the M64/50 series.

Top valve cover the same as the normally aspirated M64 series.

Oil supply line to the turbocharger.

Installation of a modified oxygen sensor control unit.

Installation of a control pressure regulator with a higher hydraulic pressure at full load.

Installation of a modified throttle body.

Installation of a modified and remapped Ignition control unit and

Installation of a modified distributor.

**Note:** Both the M30/69 and M64/50 turbocharged engines are designed to operate on 95 RON/ 85 MON fuels. However Porsche recommend that 98 RON fuel is used. The turbocharged engines are not fitted with knock regulation protection.

## Continuous injection system (CIS, K-Jetronic) (turbocharged models)

### Introduction

The CIS of the turbo models is based on previous 911 series systems. US turbo owners of the pre 964 series will not notice much difference between their 930/XX engines and the M39&69 series. However owners from the rest of the world will certainly see some major differences in the Bosch continuous fuel injection system with oxygen sensor control.

### Basic system operation

#### Fuel Distributor

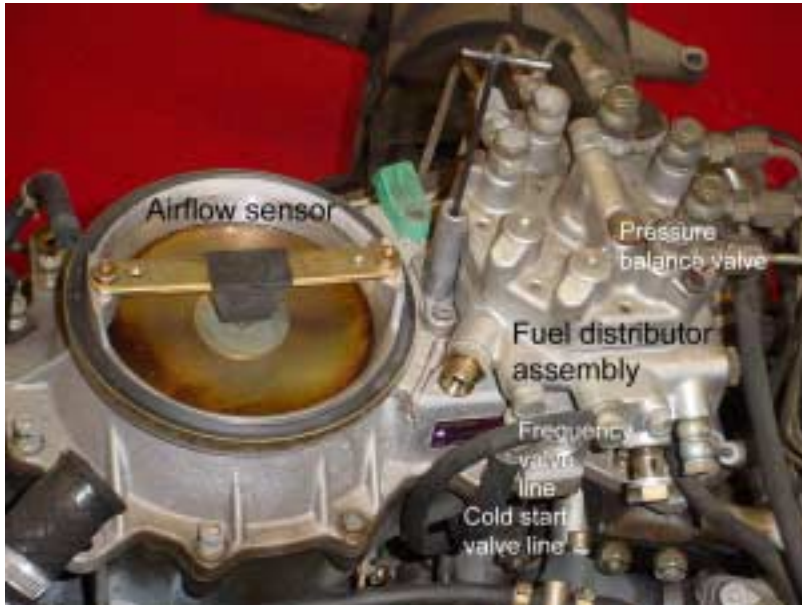

The fuel distributor is made of aluminium and is fitted with a capsule valve. In order not to retard the over-spring effect during acceleration, a capsule valve now replaces the fixed orifice. This capsule valve opens as soon as the control plunger is lifted during acceleration. A fixed orifice is used to separate the lower chamber from system pressure. Pressure in the lower chamber may now be adjusted by the frequency valve controlling

Fuel distributor and air flow sensor assembly. Photo by Jeff Curtis  
the flow to the return line. The port at the differential pressure valve, i.e. the differential pressure and, hence the quantity of fuel injected may be adapted accurately according to requirements. The fuel distributor is also fitted with a pressure balance valve. The purpose of this valve is to stop a vacuum build up in the control plunger area if the engine is switched off when it is hot. Fuel expands when it is heated up and if there is a build up of vacuum in the control plunger area, when the turbo is next started it may run too rich. The pressure balance valve is used to separate the volume above the control plunger and the return line. When the sustaining pressure drops below 0.3 bar excess pressure, the pressure balance valve opens to prevent vacuum build up in this area.

**Note:** *In the 964 Turbo system, the connector at the fuel distributor (sensor plate contact) is no longer used. The fuel pumps are controlled by an engine speed pulse from the ignition control unit.*

## Air flow sensor.

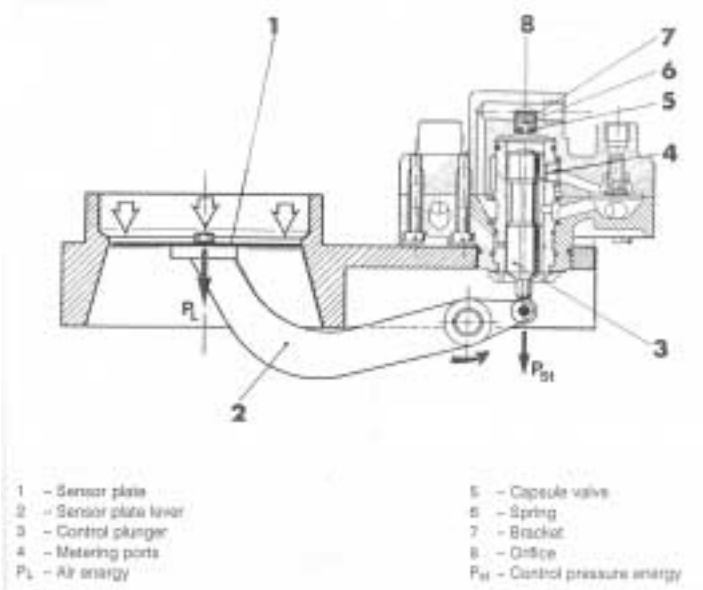

When the throttle valve opens, the air energy (PL) forces the sensor plate down and the control plunger is moved upwards. The fuel above the control plunger lifts the capsule valve i.e. flow is not directed past the orifice but is deviated around the valve. This allows the metering port to open faster to a greater degree. The pressure pulse inside the line leading to the control pressure regulator is absorbed by the flexible hose connected between the fuel distributor and control pressure regulator.

Image courtesy of Dr Ing. h. c. F. Porsche AG

### **Continuous injection without oxygen sensor control**

On 964 turbos fitted with CIS injection without oxygen sensor control, the differential valves in the fuel distributor maintain the differential pressure at a constant level irrespective of the system pressure applied. The injection quantity can therefore only be influenced by the cross-section uncovered at the metering unit.

The differential pressure between the upper and lower chamber is 0.1 bar. The diaphragm is only deflected to the extent required by the fuel quantity injected.

### **Continuous injection with oxygen sensor control (964 Turbo theory of operation).**

In order to adapt the fuel quantity injected to the desired fuel to air ratio at  $\lambda = 1$ , the pressure in the lower chambers of the fuel distributor is varied. I.e if the pressure in the lower chamber is reduced the differential pressure at the metering ports is increased. This in turn increases the fuel quantity that is injected. In order to vary the pressure inside the lower chambers, those chambers are separated from system pressure by a fixed restriction (as opposed to the standard CIS fuel distributor). Another restriction is provided to connect the lower chambers to the fuel return line. This restriction is of variable design: As long as the restriction remains open, pressure inside the lower chambers can drop. When closed the system pressure builds up inside the lower chambers. If this restriction is open and closed at a fast rate (pulsed), the pressure in the lower chamber may be varied according to the pulse-duty factor (ratio of closing time versus opening time). An electromagnetic valve (frequency valve) is used as a variable restriction device. It is controlled electrically by pulses emitted by the oxygen sensor control unit. The frequency valve is mounted in the fuel return line at the fuel distributor.

#### Frequency valve:

The frequency valve is a L-Jetronic pulse fuel injector.

The frequency valve is connected to the lower chambers of the fuel distributor and is fitted with a connection leading to the return line.

The control units feed square pulses of a constant frequency (approx 70 Hz) but of variable pulse width, the frequency valve. This pulse width is referred to as the pulse-duty factor.

In lean control means the pulse width or pulse-duty factor is below approximately 50%.

In rich control means the pulse width or pulse-duty factor is above approximately 50%.

A constant pulse-duty factor means operation without governing.

If a pulse is present at the frequency valve, the needle valve opens to permit fuel flow to the return line. The result of this is that pressure in the lower chamber of the fuel distributor drops until the frequency valve is closed again. As a result of the relatively high frequency of the pulses a medium pressure level is obtained in the lower chamber.

Fuel supplied to the injectors is directly proportional to the pressure in the lower chamber. The higher the pressure in the lower chamber the less the fuel supplied to the injectors. The lower the pulse-duty factor, the less the pressure in the lower chamber is reduced and therefore less fuel is supplied to the injectors. Lean operation. The more the frequency valve is opened, the lower the pressure in the lower chamber and more fuel is supplied to the fuel injectors. Rich operation.

#### Oxygen sensor control.

The oxygen sensor control unit is mounted underneath the left hand seat. There are two different part numbers used for the 3.3 litre engine,

ROW 965 618 103 00

USA 965 618 103 01

The Turbo 3.6 uses a modified oxygen sensor control unit. Part number This unit no processes the 0° (idle) throttle switch position. This is done to improve pickup of the engine in the low load range. Oxygen sensor speed is only doubled if the throttle opening angle exceeds 7°. The two schematics of the oxygen sensor control units show the differences.

#### Oxygen sensor.

The oxygen sensor provides the oxygen sensor control unit with information about combustion efficiency. The oxygen sensor signal is used to continuously vary the air-fuel mixture via the frequency valve. The heated zirconia (ZrO<sub>2</sub>) oxygen sensor, fully warmed up, generates a 0.1 - 0.9 volts fluctuating current in response to oxygen content in the exhaust gas. Fuel mixture is electronically regulated based on the voltage output of the sensor. Oxygen sensor out put is unreliable when cold. The heating element brings the sensor element to operating temperature under normal circumstances within 90 seconds.



964 Turbo O2 sensor installation, image courtesy of Kevin Ross

**Note:** *The O2 sensor in the turbocharged engines is not installed in the catalytic converter. It is installed in the turbocharger turbine inlet pipe.*

The oxygen sensor control unit operates in two modes, these are;

**Open loop** mode (up to approximately 90 seconds after first start of the day) is in operation when the oxygen sensor has not reached normal operating temperature or if the oxygen sensor system has failed. When operating in open loop mode, the oxygen sensor control module supplies a preprogrammed duty cycle to the frequency valve.

**Closed loop mode** (activated approximately 90 seconds after the first start of the day) becomes the normal mode of operation once the oxygen sensor has reached a temperature of 315°C (600°F) by being heated by exhaust gases and its own internal heater. The oxygen sensor signal continually modulates the frequency valve to provide the correct fuel / air ratio.

#### Acceleration enrichment

To ensure smooth acceleration even when the engine is cold, an acceleration enrichment device operating according to the pulse-duty factor is installed. The acceleration enrichment process requires the output of the oxygen sensor control unit to be provided to the acceleration enrichment control unit. This control unit is installed alongside the oxygen sensor control unit under the left hand seat.

The enrichment feature is effective only when the engine oil temperature is less than 35° (95°F). As soon as the oxygen sensor temperature switches from cold to hot, an acceleration enrichment at a pulse-duty factor of 75% is available for 0.5 seconds within 25 seconds. When the engine oil temperature exceeds 35° (95°F) the acceleration enrichment device is controlled for 2minutes after starting the engine to a pulse-duty factor of 75% for 0.5 seconds when the 0° and 7° throttle switches are open.

The acceleration enrichment process is dependent on a number of sensors and other inputs. These are;

The 35° (95°F) engine oil temperature sensor mounted in the breather housing of the crankcase.

The 15° (59°F) engine oil temperature sensor mounted in the right hand timing chain cover for the Turbo and in the breather housing of the crankcase for the Turbo 3.6.

The 0° and 7° throttle switches located in the throttle switch body

The 66° or full load throttle switch also installed in the throttle body.

### Throttle switch operation

When the 0° switch opens the pulse-duty factor is increased to 75% for 0.5 seconds. This means the air-fuel mixture is enriched during this period.

When the 7° switch opens the air-fuel mixture is enriched again.

**Note:** In the Turbo 3.6 system the enrichment at 0° or 7° is the same. 75% for 0.5 seconds.

When the 66° or full load switch is closed a signal is supplied to the oxygen sensor control unit and the pulse-duty factor is set at 50%. Full load enrichment is accomplished by lowering control pressure at the control pressure regulator.

### Full load enrichment pressures:

Turbo: When a boost pressure of 250 mbar is achieved the control pressure (hot) is reduced from  $4.5 \pm 0.11$  bar to  $3.2 \pm 0.11$  bar.

Turbo 3.6: When a boost pressure of 250 mbar is achieved the control pressure (hot) is reduced from  $4.5 \pm 0.10$  bar to  $2.9 \pm 0.15$  bar.

### Control pressure regulator.



With the introduction of the 964 Turbo a modified control pressure regulator was also introduced. The new regulator was fitted with a temperature switch and an altitude compensator. This regulator is also known as the warm up regulator.

M30/69 turbocharged engine, image courtesy of Kevin Ross.

**Note:** The Turbo 3.6 uses a modified version of this regulator, part number 965 606 106 00. The hydraulic pressure at full load has been changed for the Turbo 3.6.

### Operation:

The control pressure regulator is fitted with two heating resistors Rv1 and Rv2 that heat up a bi-metallic spring (1) housed in the control pressure regulator when the engine is running. The bi-metallic spring adjusts control pressure in the fuel distributor via a valve plate. The built in temperature switch (t) is designed to remain open at temperatures below +15° (59°F). When the switch contacts open, the ground connection of heating resistor Rv1 goes open circuit. When the engine is started whilst ambient temperature at the control pressure regulator is below 15° (59°F), voltage is applied initially only at resistor Rv2; the bi-metallic spring heats up only slowly and control pressure builds up gradually. When the ambient temperature exceeds 15° (59°F), the temperature switch closes to ground. Both resistors Rv1 and Rv2 are then connected in parallel. This increases the heating efficiency and heat output. As a result the bi-metallic spring heats up faster and the control pressure regulator settles more rapidly.

### Turbo control pressures:

Initial control pressure at 20° (68°F);

2.8 ± 0.15 bar

Operating control pressure

4.5 ± 0.11 bar

### Turbo 3.6 control pressures:

Initial control pressure at 20° (68°F);

3.0 ± 0.15 bar

Operating control pressure

4.5 ± 0.10 bar

### Altitude compensation:

An altitude compensator is built into the new control pressure regulator. Atmospheric pressure acting on the altitude capsule located in the control pressure regulator is taken up at the air cleaner body and is applied to the altitude capsule across the venting line of the control pressure regulator. The altitude capsule acts on the valve plate of the control pressure regulator, thus influencing control pressure.

Cold start valve Used to inject additional fuel during a cold start. This is a solenoid valve installed into the intake plenum.

Thermo-Time switch. The purpose of this switch is to control the operation of the cold start valve. The switch itself consists of a bi-metallic switch which is electrically heated. When the engine is cold or less than 15° (59°F) the bi-metallic contacts in the switch are closed and when the starter is activated, a ground via these contacts is supplied to the cold valve solenoid which will then close. More fuel is then injected into the engine. When the temperature of the bi-metallic strip exceeds 15° (59°F) it opens and removes the ground from the cold start valve and it opens. This is to limit valve operation and prevent flooding. The valve is only open for a few seconds on a cold start. This switch is mounted in the left hand chain housing in the Turbo and in Turbo 3.6 it is mounted in the breather housing of the crankcase .

Auxiliary air regulator: To compensate for increased friction inside a cold engine. The



throttle valve is bypassed by this temperature controlled regulator assembly. Again this regulator uses electrical current to warm a heating element and causes the bimetallic strip to bend gradually, closing the rotary valve and cutting off additional air.

M30/69 turbocharged engine, image courtesy of Kevin Ross

Vacuum limiter valve: During overrun, the engine must be kept from running on an



excessively rich fuel/air mixture. A vacuum controlled diaphragm valve has been installed to prevent this. The vacuum limiting valve bypasses the throttle valve and supplies additional or auxiliary air required to ensure optimum combustion and not to allow the engine to run too rich.

M30/69 turbocharged engine, image courtesy of Patrik Selestam

#### Intercooler:

Installed on top of the throttle housing, is the new and larger intercooler. This new intercooler has an increased cooling surface to improve air intake into the cylinders. The purpose of the intercooler is to increase the density of the air entering the engine intake system. This is achieved by simply cooling the pressurised turbo-charged air. There are number of switches and sensors installed into the intercooler. These are;

Boost pressure sensor: This sensor supplies the data to the boost indication system, contained in the trip computer assembly in the tachometer. Boost (measured in bars) is the default display for the Turbo trip computer.

Boost pressure switch: This is a pressure safety switch. When turbo boost reaches a preset maximum the switch opens and cuts off power to the fuel pumps. This switch operates at 1.1 to 1.4 bar. The pulse output is then sent to the turbo control unit which removes the earth to the fuel pumps.

Temperature sensor: he signal from this sensor is used by the oxygen sensor control unit to fine-tune the fuel mixture. This sensor is a positive temperature co-efficient (PTC) sensor. This means the resistance increases with an increase in temperature.

Re-circulating air valve (also known as the Compressor bypass valve)

This valve is designed to stop the turbocharger from operating against a closed throttle valve. Te re-circulating valve is vacuum controlled and it fitted between the intake and thrust sides of the turbocharger. The re-circulating air valve is located behind the intercooler on the left hand side of the engine.

**Note:** *In order to improve valve reliability the original Bosch version is often replaced with aftermarket versions such as the one manufactured by Forge.*

## Turbocharged engine controls:

Turbo engine management relay and module locations are listed in the table below.

Turbo engine relay and control unit locations  
Component Location



Fuel pump relay (R61) Central electric (main fuse/relay panel) located at the right rear of the luggage compartment.

Image courtesy of Steve Shanks

Oxygen sensor relay Fuse/relay carrier, left side of the engine compartment

Oxygen sensor control unit installed under the left seat

Acceleration enrichment control unit installed under the left seat

Turbocharger control unit installed under the left seat

### Turbocharger control unit

The turbo control unit, located under the left seat, controls;

2 fuel pumps

Safety cut out circuits of the fuel pumps

Boost pressure safety circuit

Ignition delay relay

Power supply for

1. oxygen sensor control unit which includes switched from open to closed loop operation.
2. acceleration enrichment control unit
3. ignition system
4. control pressure regulator
5. auxiliary air regulator
6. frequency valve at the fuel distributor
7. oxygen sensor heater

### Turbo control unit modes:

The program stored in the microprocessor of the turbo control unit covers two modes;

#### **Start mode:**

Is recognised by the microprocessor on the basis of engine speed, i.e. the period length of the pulse generator signal. The firing point is triggered at the positive edge of the pulse generator signal at approximately 15° BTDC.

#### **Operating mode:**

The control unit switches from start to operating mode as soon as the preset threshold of 630 rpm is exceeded. When engine speed drops below 330 rpm, the idle

firing angle is  $0^\circ \pm 3^\circ$  with the throttle switch at  $0^\circ$  (closed) the turbo control unit will switch from operating to start mode.

When the turbo control unit is switched to operating mode it works in conjunction with an operating ignition map stored in the ignition control unit. This combination of control unit data and ignition control unit data determines the optimum firing point for each operating condition based on engine load, engine speed, engine temperature, intake air temperature,  $0^\circ$  throttle switch and fuel selector switch position.

#### Ignition delay:

In order to ensure complete combustion of the fuel that may have been injected before the engine is turned off. The ignition will remain on for approximately 5 seconds after the engine is turned off.



Image courtesy of Steve Shanks

### **Other engine sensors and information sources**

#### Fuel selector switch:

In certain countries fuel octane levels lower than the recommended RON 95 may be mandated for use in automobiles. In order to avoid random ignition taking place in the engine, the ignition may be retarded by  $2.3^\circ$  from a certain engine load via a 2-pin code plug using jumper part number 944 612 525 01.

#### Manifold pressure sensor:

When starting the engine, the manifold pressure sensor is checked for short-circuiting and open circuit, i.e. the firing angle corresponding to the full-load curve (1,800 mbar). If output pressure is below 750 mbar it will be short circuit or above 1250 mbar it will be open circuit.

#### Electronic idle stabiliser

If the idle speed drops below a certain value a stabilising feature becomes effective by moving the firing angle in an "advance" direction.

#### Signal sensor

This sensor is identical to the flywheel speed/reference mark sensor used in the normally aspirated 964 series of engines. This sensor measures flywheel speed and supplies its signal to the ignition control unit.

#### Engine temperature sensor

A standard negative temperature co-efficient (NTC) sensor that measures the engine oil temperature (engine temperature). It is mounted into the crankcase. This sensor is used to adjust ignition timing in accordance with temperature. The condition of this

sensor is monitored and if it goes open circuit the engine temperature value from the sensor is ignored and a preset value is used.

#### Idle switch

The 0° throttle switch keeps the ignition control unit informed on the idle and overrun mode of the engine.

#### Engine speed governor:

To protect the engine from excessive speeds, the turbo control unit interrupts the ground pulse to the fuel pump relay at 6,800 rpm, causing the fuel pumps to be de-energised.

### **Fuel Delivery**

#### Fuel pumps:

The turbo has two fuel pumps. One installed directly behind the fuel tank and the other, in the right hand side of the luggage compartment. Both pumps are controlled by the fuel pump relay R61.

Terminal 30 of the fuel pump relay is connected to the positive side of the battery. Voltage is present at terminal 86 when the ignition is switched on. When the engine is started, a rpm pulse (equivalent to approximately 30 rpm) is fed from the ignition control unit to the turbo control unit. This in turn supplies a ground pulse to the relay coil of terminal 85 of the fuel pump relay. The relay contacts close, causing



voltage to be present at the fuel pump fuses and the fuel pumps respectively across terminal 87. This wiring set up prevents the fuel pumps from operating when the ignition is turned on and the engine is not running.

Image courtesy of Steve Shanks

**Note:** The turbo is fitted with 1 fuel filter and 1 fuel pressure reservoir. The single fuel filter is connected between the fuel pressure reservoir and the fuel distributor.

#### Fuel injectors

CIS mechanical fuel injectors are precision nozzles. When the fuel system delivers fuel pressure within the normal pressure range, injector nozzles open and continuously deliver atomized fuel into the intake ports. Each fuel injector is mounted into an insert which is screwed into the intake runner. The injector is held in place by a thick sealing O-ring.

#### **Carbon cannister fuel venting system: (also known as the fuel tank breather system):**

To protect the environment and to reduce specific fuel consumption, all 964s are fitted with a tank breather or carbon cannister system. Fuel vapour is collected in a carbon canister and fed back to the engine if specific requirements are met.

### System operation:

The fuel vapours are routed from the fuel tank across the expansion tank and the rollover safety valve reservoir through the bleeder hose to the carbon canister. A purge air line ends in the left-hand rear wheel housing. The vent line of the carbon canister is connected to the air filter assembly in the normally aspirated 964s and in the Turbo. In the Turbo 3.6 system the carbon canister vent line is fed to the intake side of the turbocharger across three in-line vacuum controlled valves. These valves are;

Temperature valve which remains open when the engine oil temperature exceeds 40° C and provides a vacuum connection between the throttle body (2° bore) and the switch off valve.

Anti-run-on-valve which is triggered by the temperature valve and remains opens at engine oil temperatures above 40° C and with a minimum throttle deflection of 2° and the engine is not in the boost pressure range.

Control valve which is connected directly to the intake manifold below the throttle across a separate vacuum line. All three valves are connected in series and the carbon canister contents can only be drawn off and the air-fuel mixture influenced under the following conditions.

Engine oil temperature greater than 40° C.

Throttle is opened by at least 2° and

The engine is **not** in the boost pressure range

### **Ignition system**

The 964 series of turbocharged engines, the M30/69 and M64/50 use a similar but not exactly identical, ignition system.

### System components:

A single engine driven distributor assembly.



One ignition transformer with built in final driver stage. The ignition transformer is mounted above and to the right of the distributor assembly. Six spark plugs. Six spark plug lead set. A Bosch EZ69 electronic ignition control unit which is mounted to the right of the engine bay electrical distribution panel. Ignition control unit relay which is installed inside the engine bay electrical distribution panel. Relay #1.

Image courtesy of Michael Behrman

### **M30/69 engine:**

The ignition system of this engine series is based upon the system installed on the 968/68 turbocharged engine. Most of the parts used are 930 part numbers except for the ignition transformer and the ignition control unit.

The changes introduced for the 964-770 turbo are;

The installation of an electronic ignition control unit with pressure sensor which provides pre-programmed dwell angle and timing maps mixed with air pressure or engine load from the throttle body to provide digital spark control. The ignition control unit part number is 965 602 706 01.



Ignition control unit, image courtesy of Steve Shanks

#### **M64/50 engine:**

Whilst similar to the earlier M30/69 engine ignition system some changes to the M64/50 were introduced the 964 Turbo 3.6 made its appearance in model year 1993. These differences are;

The installation of a new ignition control unit with modified ignition mapping pre-programmed into the control unit. The new part number is 965 602 706 02.

The pressure sensor line was relocated to the downstream section of the throttle body. This was done to reduce the impacts of full load pulsations on the pressure sensor installed in the control unit.

#### Distributor modifications:

Due to a modification to the cooling fan housing a new distributor assembly with a longer drive shaft was installed.

The centrifugal weights (as per the normally aspirated dual ignition system assembly) were installed to ensure overlap between the distributor rotor arm and the individual distributor cap contacts (each spark plug) at high distributor speeds (large ignition advance). These weights help adjust the rotor in the direction of rotation. Helps the rotor arm keep up and not lag behind the engine rpm.

The installation position of the distributor rotor in firing TDC of cylinder #1 was also modified. The notch in the distributor housing is now opposite the fastening nut. This modification also caused the spark plug lead positions to be changed.

The new distributor part number is 965 602 024 00.

The spark plugs used on the M64/50 are the Bosch FR 6 LDC. These are longer life and more efficient spark plugs with a replacement interval of 40,000 km (25,000 miles).

**Note:** *These new spark plugs were installed in all model year 1994 versions of the 964. They can be retro-fitted to all earlier models.*

## Basic operation of the electronic ignition control unit (Bosch EZ69).

(Applicable to all 964 Turbo versions).

The control unit receives inputs from;  
Flywheel speed sensor (pulse generator in the parts catalogue).  
Fuel octane code.  
Boost air temperature.  
0° throttle switch.  
Power via the relay.

The control unit also has a pressure sensor installed. This pressure sensor is connected to the throttle body. The purpose of the pressure sensor is to provide engine load (amount and pressure of air entering the engine) data to the ignition control unit.

**Note:** *The pressure sensor in the ignition control unit has the same role as the air flow sensor in the normally aspirated engines.*

The control unit then calculates the correct dwell angle and when to fire each spark plug based in calculations from all the electronic inputs, the pressure input and the pre-programmed digital maps.

The outputs from the control unit are,  
Signal at the ignition transformer

Engine speed (rpm) to the turbo boost control unit and to the tachometer (rev counter).

### Turbo exhaust system

The exhaust system of the turbocharged engines (M30/69 and M64/50) serves two purposes;

To allow exhaust gases to leave the engine and enter the atmosphere and  
To drive the turbocharger.

The turbocharged exhaust system is fitted with a metal three-way catalytic converter. The catalytic converter is mounted where the primary (or intermediate muffler) is mounted on normally aspirated 964 is installed.

#### **Exhaust system operation:**

The engine exhaust gases pass from the exhaust manifold into the heat exchangers.



The exhaust gases are then routed to the turbine of the turbocharger. The exhaust gas then pass into the catalytic converter and into the muffler system (front and rear) and then exit the system from the right hand exhaust pipe.

Right hand side of the exhaust, image courtesy of Steve Shanks



The left exhaust pipe is connected to the boost control valve (waste gate) and used to dump the excess boost pressure to the atmosphere. There is a secondary catalytic converter connected between the waste gate and the left hand exhaust tip. This is required because there is a direct input connection between the boost control valve and the exhaust system.

*Note: To meet very strict Swiss emission and noise requirements, turbocharged 964s sold in Switzerland are equipped with some different exhaust system components.*

Left side exhaust, image courtesy of Steve Shanks.

### **Secondary Air injection:**

Secondary air injection is provided by the secondary air injection pump. This pump is belt-driven off the left camshaft. The purpose of this secondary air pump is to reduce emissions and to enable the catalytic converter and the oxygen sensor to heat up more rapidly to operating temperature. Fresh air is drawn in by the air injection pump and is supplied to the air diverter valve as long as the engine oil temperature is below 35° (95°F). The diverter valves control flow of secondary air to the exhaust ports. When the engine is cold, the valves are open to increase burning of excess fuel used for cold start and cold running. A check valve in the system keeps exhaust gases



from flowing back through the system. If the engine is started with an engine oil temperature above 35° (95°F), the fresh air supplied by the secondary air pump is supplied to the catalytic converter, resulting in improved emission treatment.

Air pump and secondary injection components. Photo by Kevin Ross

## Turbocharger

The reason for installing a turbocharger onto an engine is to obtain the maximum horsepower available from it. The basic principle of the turbocharger is to force-feed the engine with additional air and fuel. An increased volume of air and fuel in the combustion chamber of the engine provides more combustion power. Turbo-charging is a means to *dynamically* increase the engine compression ratio.

The turbocharger is powered by exhaust gases that are already on the way out of the engine, effectively making free additional power. Boost is the amount of pressure created by the turbocharger. Higher boost pressures translate into higher power output.

In the sports cars world, Porsche was a pioneer in turbo-charging. Porsche built the first series production run of turbocharged sports cars, releasing them in 1975 as the 930. On the road, nothing could touch them, and for many years, they remained the fastest sports cars available.

This technology and expertise was integrated into the 964 series for the 1991 model year. The turbocharger used for the standard Turbo and Turbo 3.6 was the same as the one used on the 930/68 engine, part number 930 123 003 02. The 20 Turbo S2s were delivered to the USA with the same part number turbocharger but this was removed and replaced with a new larger assembly by Andial. The Turbo S and the Turbo 3.6S were fitted with new larger turbochargers at the factory.

### Boost pressure control valve (also known as the Waste gate)

The boost pressure control valve has two ports. The lower port allows boost



pressure to come in underneath the diaphragm and spring valve. As long as boost pressure from the turbocharger remains below the spring tension value which is equivalent to a specific boost pressure, the boosted air is permitted to continue on its way to the intercooler. Once the boost pressure has overcome the spring tension i.e. exceeded the allowable boost pressure value, a valve attached to the diaphragm and plates is pulled up. This then bypasses boost pressure through the control valve through a small catalytic converter and an exhaust pipe to atmosphere. The top port of the waste gate allows the air above the diaphragm to vent as pressure is built under it.

Image courtesy of Stephen Kaspar

### Catalytic converter

The catalytic converter is a component of the emission control system. Once exhaust gasses enter the catalytic converter, chemical reactions occur within it that ensure that carbon monoxide (CO) and unburned hydrocarbons (HC) are converted to carbon dioxide (CO<sub>2</sub>) and water vapor. A catalytic converter operates at 60 to 90% efficiency, depending upon age. This means that the amount of exhaust emissions that enter



the catalytic converter are reduced approximately by this percentage. A catalytic converter has a limited life expectancy which depends upon use and external environmental conditions.

Image courtesy of Steve Shanks

**Note:** Japanese versions of the 964 used a different catalytic converter from the rest of the world.

**Note:** Option M150 turbocharged engines do not have a catalytic converter installed.

**Caution:** The catalytic converters can be damaged by push- or tow-starting, misfiring of the engine, turning the ignition off whilst still in motion or by other unusual operating conditions.

- Ensure that no unburned fuel enters the catalytic converter. If this occurs, overheating of the converter will result. In the worse case scenario, a fire could result.

## Turbo engine lubrication system

All the engines in the entire 964 series are dry-sumped. This means that the oil is stored externally to the engine in a remotely located oil tank. Oil is drawn out of this tank and through the engine only when it is running. When the engine is not running, most of the oil is returned to the oil tank. Approximately 2 litres remains in the engine and oil cooler system after the engine is turned off. This is important to remember at oil change time. Overfilling with oil can cause problems which are described elsewhere in this book.

**Caution:** During a routine oil change service, filling the engine with more than 11 litres of oil will cause the system to be overfilled. Smoke out of the exhaust will result after each start.

The components of the 3.3 litre turbocharged engine (M30/69) lubrication system are:

- Engine driven oil pump (inside crankcase)

- Oil filter
- Oil tank
- Oil thermostat and plumbing
- Oil cooler assembly and plumbing
- Oil temperature sensor
- Oil pressure switch

The components of the 3.6 litre turbocharged engine (M64/50) lubrication system are the same as the M30/69 engine except the left hand chain tensioner oil gallery has been adapted to supply oil to the turbocharger oil lubrication system.

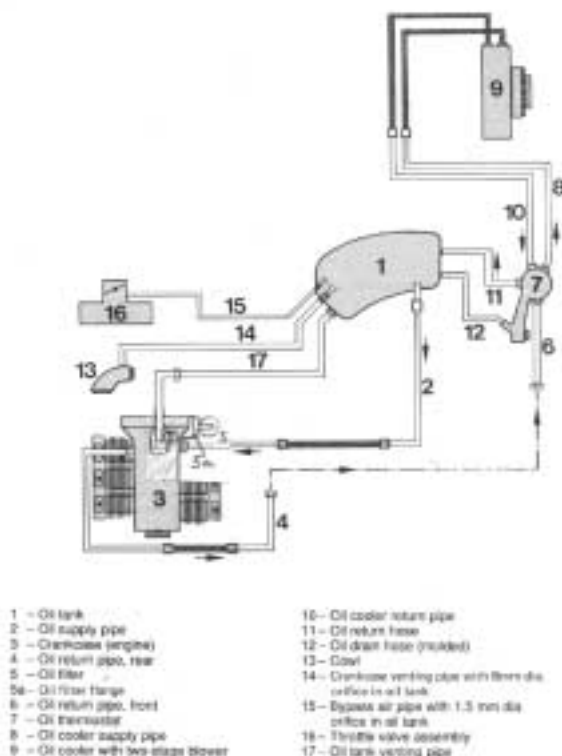

Image courtesy of Dr. Ing. h. c. F. Porsche AG

### Oil circuit description:

The turbocharger is lubricated via a steel pipe combined with a flexible hose. The oil enters the circuit across a union between the main engine oil-gallery and the turbocharger. The fitting at the crankcase features a ball valve which acts as a check valve.

Once the oil has passed through the turbocharger, the oil flows into an oil trap and then is returned to the oil tank via the camshaft driven oil pump. The crankcase breather line is fitted with a branch line to direct the return flow to the oil tank.

The Turbo 3.6 model uses the same lubrication system except for differences caused by the design of the M64 series engine. These are;

The connection to the turbo oil system is located on the oil supply galley at a connection in the left side chain tensioner. Previously unused (blocked off in the

normally aspirated M64 engines) oil galleries are opened to provide the oil to the turbocharger.

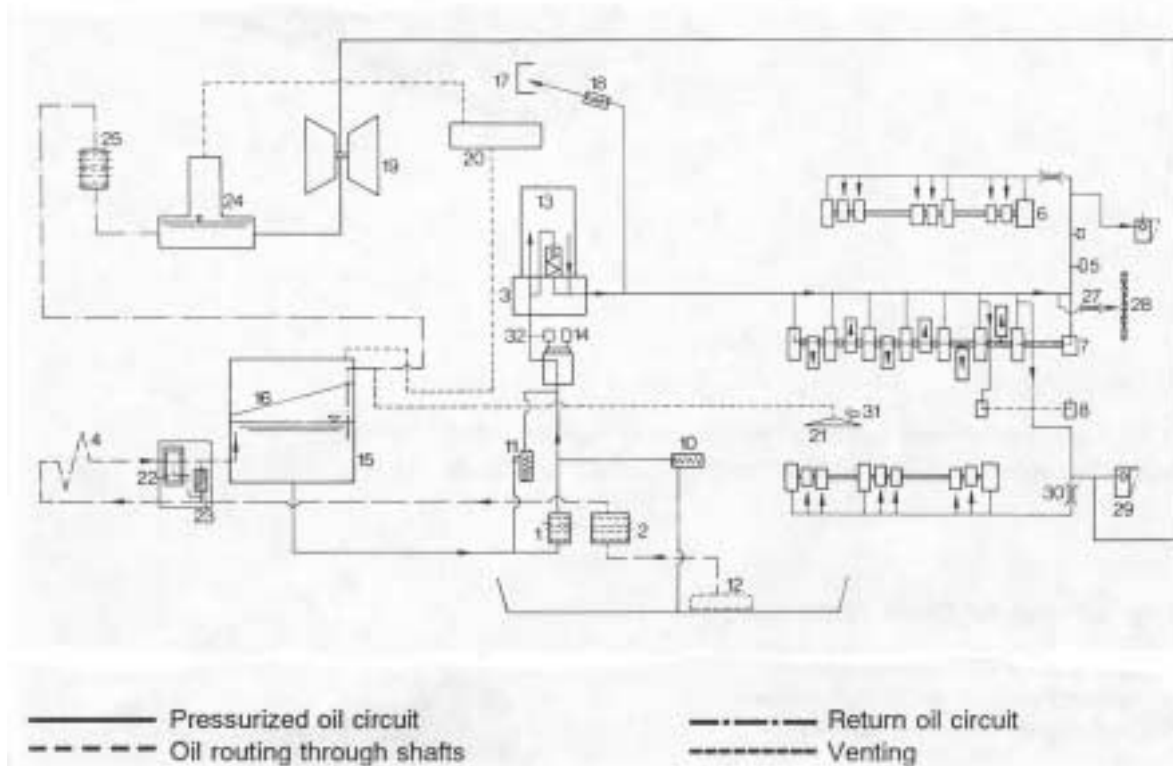

Image courtesy of Dr. Ing. h. c. F. Porsche AG

This 964 Turbo engines and systems review, was not possible without the hugely valuable and special contributions of the following;

Dr. Ing. h.c. F. Porsche AG  
Steve Shanks  
Stephen Kaspar  
Michael Behrman

The contents of this document are intended for the personal DIY use of 964 owners. The contents in full or in part of this document may not be reproduced or used in any way than already described without the express permission of the author.

Copyright April 2<sup>nd</sup> 2003.